

H801RC Instructions



1. Abstract

H801RC is a slave controller that transmits data based on Ethernet Protocol, data is input from mater controller or computer to NET1 and output from NET2. H801RC has eight output ports and drives maximum 8192 pixels, and can be connected to computer or master controller.

2. Supported Driver Chips

LPD6803, LPD8806, LPD6812, LPD6813, LPD1882, LPD1889, LPD1883, LPD1886, DMX512, HDMX, APA102, P9813, LD1510, LD1512, LD1530, LD1532, UCS6909, UCS6912, UCS1903, UCS1909, UCS1912, WS2801, WS2803, WS2811, DZ2809, SM16716, TLS3001, TLS3002, TM1812, TM1809, TM1804, TM1803, TM1914, TM1926, TM1829, TM1906, INK1003, BS0825, BS0815, BS0901, LY6620, DM412, DM413, DM114, DM115, DM13C, DM134, DM135, DM136, 74HC595, 6B595, MBI6023, MBI6024, MBI5001, MBI5168, MBI5016, MBI5026, MBI5027, TB62726, TB62706, ST2221A, ST2221C,

XLT5026, ZQL9712, ZQL9712HV, etc.

Offline auxiliary software is “LED Build Software”; online auxiliary software is “LED Studio Software”.

3. Performance

- (1). Eight output ports drive maximum 8192 pixels. Pixel number that each port can drive is 8192 divided by number of using ports. Port number could be one, two, four, or eight. (means you can choose “one slave with a line”, “four slave with a line”, or “eight slave with a line” in LED Build Software)
- (2). Working online or offline, H801RC can be connected to computer, master controller, switch or photoelectric converter.
- (3). High synchronization performance, transmission delay of adjacent slave controller is less than 400 ns, image has no tearing or mosaic phenomenon.
- (4). Good control effect, gray scale is under precisely control.
- (5). Far transmission distance. Data transmitted based on standard Ethernet protocol and the nominal transmission distance between adjacent controllers is up to 100 meters.
- (6). Clock scanning frequency is adjustable from 100K to 50M Hz.
- (7). Using gray scale and inverse gamma correction technology to make actual displaying effect more consistent with human physiological sensation.

4. Operation Instruction

- (1). Connect Net1 to the network interface of a computer or a master, and Net2 to Net1 of next H801RC.
- (2). Crossover network cable is recommended in engineering. The following is the wiring sequence.

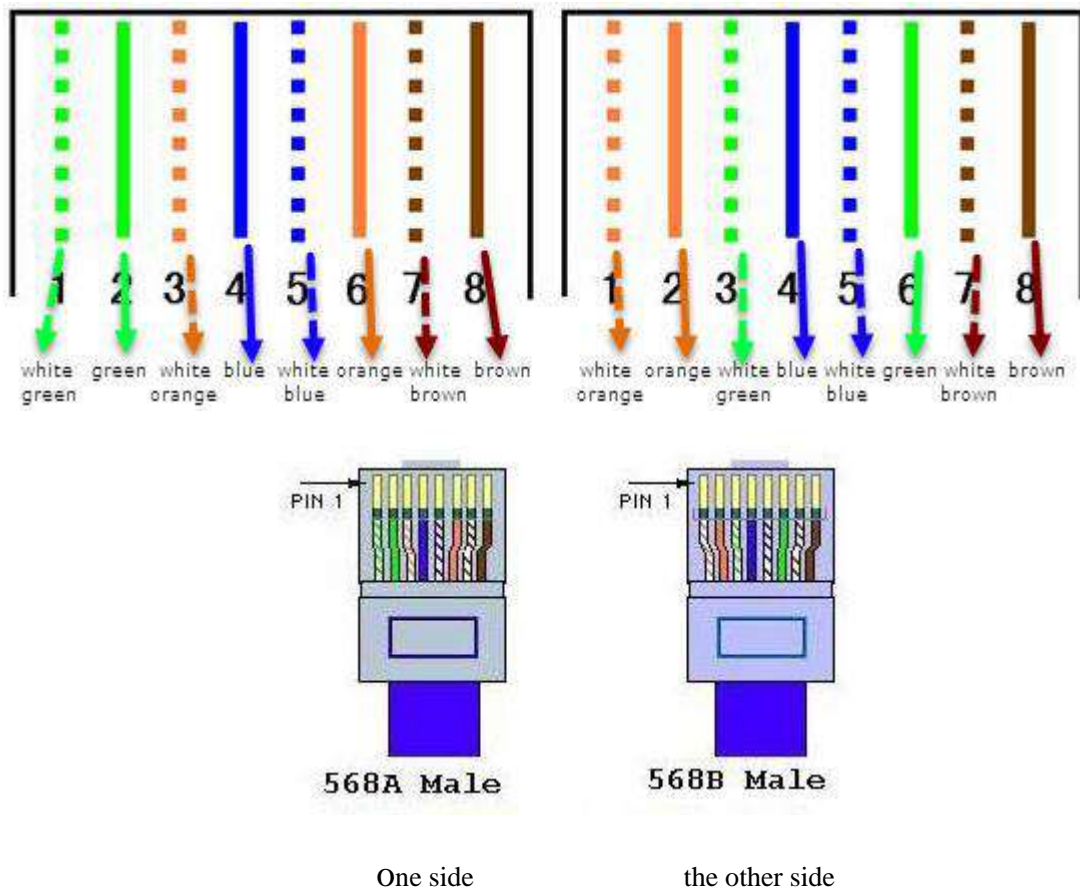

- (3). When setting sculpt, you can choose “one line with a slave”, “four line with a slave”, or “eight line with a slave”. Line number is port number.

(4). There are two indicator lights besides the network interfaces, the upper one is green **NET**, which will flash when H801RC detects data from network cable, the below one is red **ACT**, which will flash when controller output data to lamp. Flash frequency is effected by data transmit speed.

(5). When H801RC is connected to computer, don't choose "obtain an IP address automatically" but choose "Use the following IP address", enter an IP address as follows, Subnet mask is 255.255.255.0, remember check "validate setting upon exit".



5. Ports definition

GND CLK1 DAT1	GND CLK2 DAT2	GND CLK3 DAT3	GND CLK4 DAT4	GND CLK5 DAT5	GND CLK6 DAT6	GND CLK7 DAT7	GND CLK8 DAT8	For single-line chips (WS2811, etc) or double-line chips (LPD6803, etc)
GND D-1 D+1	GND D-2 D+2	GND D-3 D+3	GND D-4 D+4	GND D-5 D+5	GND D-6 D+6	GND D-7 D+7	GND D-8 D+8	For DMX512
GND CLK1 DAT1	GND LAT1 OE1	GND CLK2 DAT2	GND LAT2 OE2	GND CLK3 DAT3	GND LAT3 OE3	GND CLK4 DAT4	GND LAT4 OE4	For four-line chips (74HC595, etc)

6. Connection Diagram

connect to master
controller, switch, etc

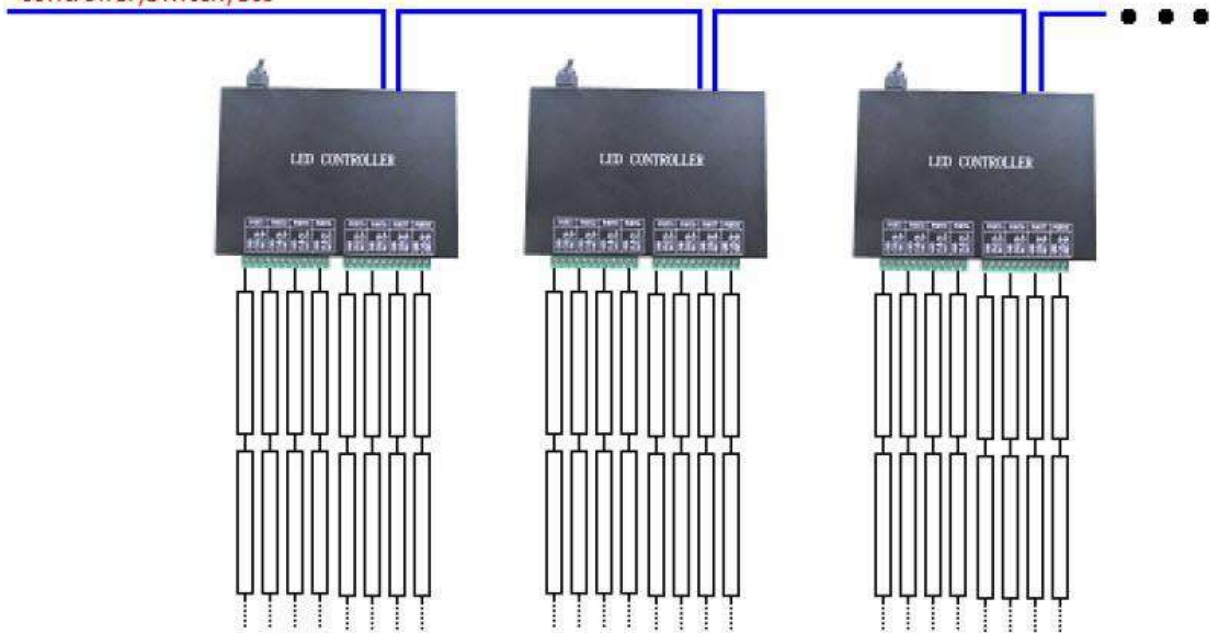

Use optical fiber to prolong transmit distance

connect to master
controller, switch, etc

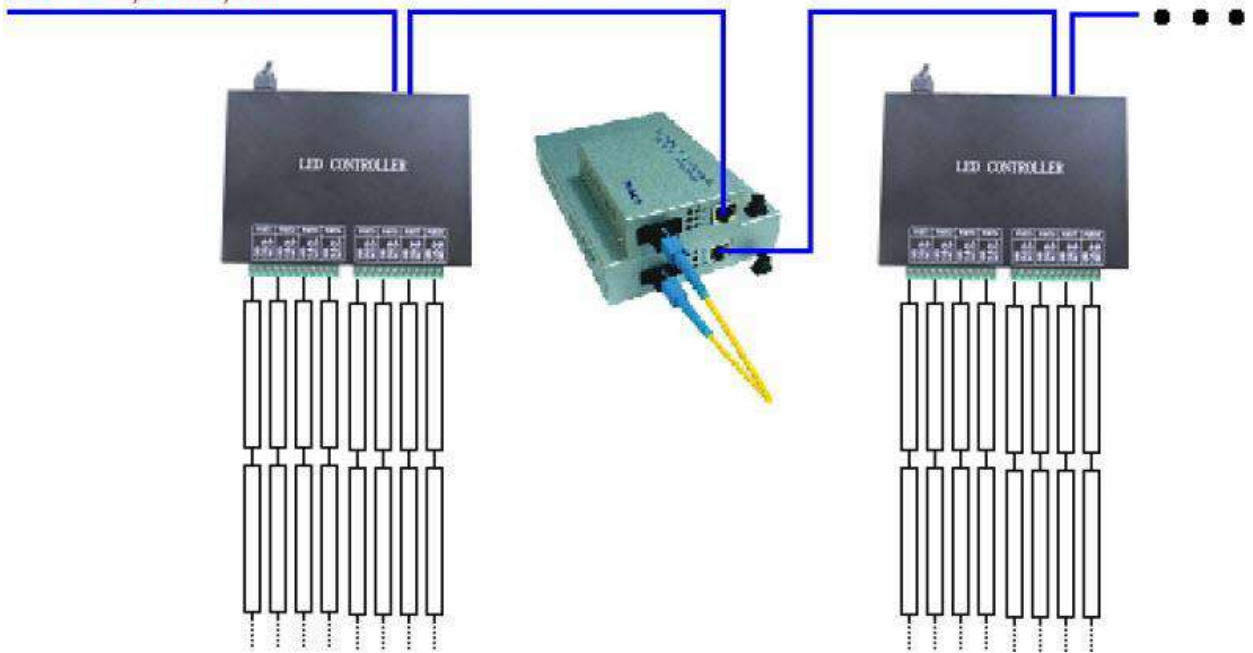

7. Specifications

Input Voltage	AC220V
Power Consumption	1.5W
Drive pixels	8192
Weight	1Kg
Working Temperature	-20C°--75C°
Dimension	L189 x W123 x H40
Installation Hole Distance	100mm
Carton Size	L205 x W168 x H69