

RGBW Dimmer User Manual



(Please read through this manual carefully before use)

1. Brief Introduction

Welcome to use this RGBW controller, It is a universal high performance power controller for entire color changing which adopted PWM (Pulse-Width-Modulation) controlling technology, with dimming rotary knobs, lamplight soft and stable, without flicker. Controls all common anode RGBW constant voltage LED lights such as :RGBW LED module, led strip, LED SMD tape and so on.

2. Specifications

Model	RGBW Dimmer
Input voltage	DC12V-DC24V
Output current	6A×4CH
Output power	288W(12V)/576W(24V)
Scale levels	4096 level x4
Dimension	L176×W46×H30(mm)
Weight	130g

3. Function and feature

1. Automatically adapt to LED light which works from DC12V-24V.
2. 4 dimming rotary knobs, DIY your favorite color. Lamplight soft and stable, without flicker.
3. Work with power repeater, the power can be amplified unlimitedly.
4. Power loss memory function.

4. Safety warnings

1. To ensure your safety and product properly usage, please read the user manual carefully.
2. To avoid installed the product in minefield, strong magnetic field and high voltage area.
3. To ensure the wiring is correct and firm avoiding short circuit damages to components and cause fire.
4. Please install the product in a well ventilated area to ensure appropriate temperature environment.
5. The product must be worked with DC constant voltage power supply. Please check the consistence of input power with the product, if the output voltage of the power comply with that of the product.
6. Connect the wire with the power on is forbidden. Ensure proper wiring first then check to ensure no short-circuit, then power on!
7. Don't repair it by yourself whenever an error occur. Contact the supplier for any inquiry.

5. Installation and usage

1. Dimension

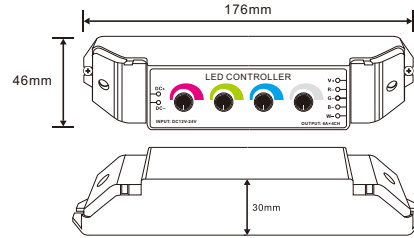

2. Conjunction diagram

1) Conjunction diagram of LED constant voltage strip

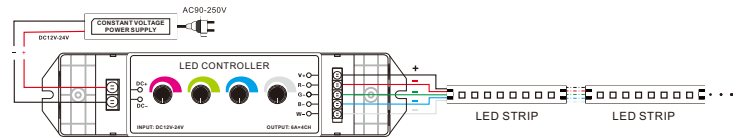

2) Dimmer to power repeater (the controller and the amplifier can share the same power supply)

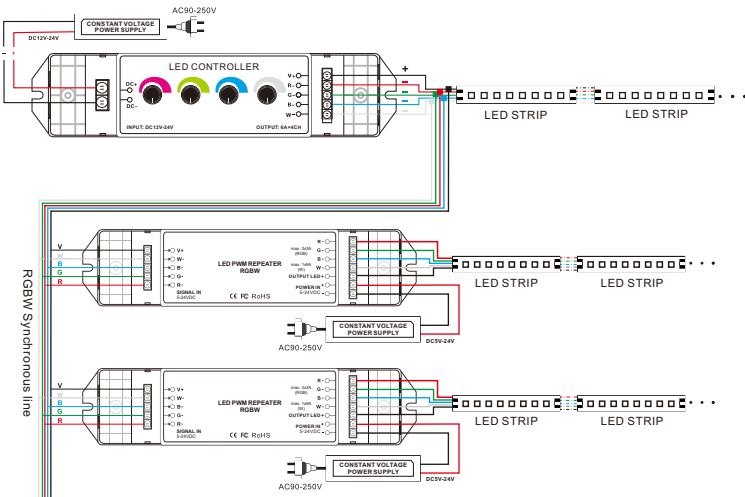

6. Exception Handles

Malfunction	Causation	Solution
No Light	1.No power from the socket	1.Check the socket
	2.Reverse connection of power +/-	2.Modify the connection
	3. Wrong or loose connection	3.Check connection
Wrong color	4.RGB wrong wiring	4.Re-wire RGB
Brightness of the LED is not even	5.Output wire too long, voltage drops	5. Reduce cable or use loop connection
	6.Wire diameter too slim, voltage drops	6.calculate the current and change to a wider wire
	7.Power supplier overloads	7.Change to another large power supplier
	8.Controller overload	8.Add a power repeater

7. After Sales

From the day you purchase our products within 3 years, if being used properly in accordance with the instruction, and quality problems occur, we provide free repair or replacement services except the following cases:

- 1.Any defects caused by wrong operations.
- 2.Any damages caused by inappropriate power supply or abnormal voltage.
- 3.Any damages caused by unauthorized removal, maintenance, modifying circuit, incorrect connections and replacing chips.
- 4.Any damages due to transportation, breaking, flooded water after the purchase.
- 5.Any damages caused by earthquake, fire, flood, lightning strike etc force majeure of natural disasters.
- 6.Any damages caused by negligence, inappropriate storing at high temperature and humidity environment or near harmful chemicals.

8. Kindly Reminder

Power Source Selection:

Power source must be DC constant voltage type of power supply. Due to the efficient output in some power supplies are only 80% of total, so please select at least 20% higher output power supply than the consumption of LED lights.