

(2) Wiring diagram of Master Mode:(Only one decoder is allowed to work as a master)

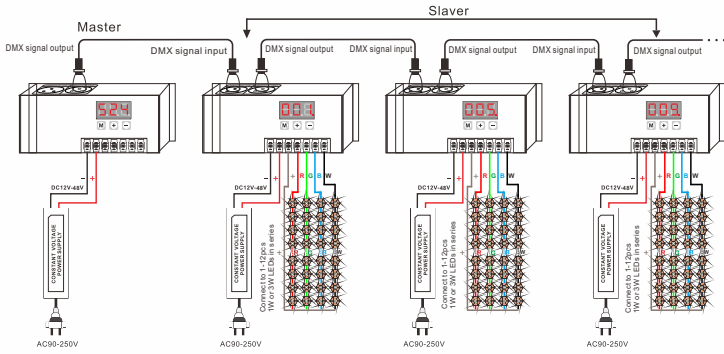

7. Exception Handles

Malfunction	Reasons	Solutions
No light	1. no power supply	1. Check power supply
	2. Reversed polarity	2. Reverse it
	3. Signal terminal not connected or reversed	3. Signal terminal not connected or reversed
	4. Long circuit such as longer than 200m	4. Add signal terminator or amplifier
Wrong color	5. RGBW wrong wiring	5. Re-wire RGBW
	6. Wrong input of decoder address	6. Re-input
One or several color(s) slight but no change	7. Signal terminator wrongly connected or reversed	7. Check the wiring re-wire it properly
	8. Long circuit such as longer than 200m	8. Add signal terminator or amplifier
Abnormal shake during	9. Signal terminator not be properly connected	9. Connect it properly
	10. Long circuit such as longer than 200m	10. Add DMX signal transmitter or splitter

8. After Sales

From the day you purchase our products within 3 years, if being used properly in accordance with the instruction, and quality problems occur, we provide free repair or replacement services except the following cases:

- Any defects caused by wrong operations.
- Any damages caused by inappropriate power supply or abnormal voltage.
- Any damages caused by unauthorized removal, maintenance, modifying circuit, incorrect connections and replacing chips.
- Any damages due to transportation, breaking, flooded water after the purchase.
- Any damages caused by earthquake, fire, flood, lightning strike etc force majeure of natural disasters.
- Any damages caused by negligence, inappropriate storing at high temperature and humidity environment or near harmful chemicals.

Constant Current DMX512 Decoder User Manual



(Please read through this manual carefully before use)

Update Time: 2019.4.15

1. Brief Introduction

Welcome to use the DMX512 Constant Current Decoder which is developed only for constant current LED lamps. It adopted advanced micro-computer control technology to transfer standard DMX512/1990 signal to PWM signal. User can choose 1-4 output channels, 4096 Grey Scales. Multiple DMX512 signal interface.

2. Specifications

Model	350mA	700mA
Input voltage	DC12V-DC48V	
Max load current	350mA/load X4	700mA/load X4
Max output power	12V: 1-3pcs 1W LED	12V: 1-3pcs 3W LED
	24V: 1-6pcs 1W LED	24V: 1-6pcs 3W LED
	36V: 1-9pcs 1W LED	36V: 1-9pcs 3W LED
	48V: 1-12pcs 1W LED	48V: 1-12pcs 3W LED
Grey Scale	4096 levels X4	
Input Signal	DMX512/1990	
Output Signal	Constant Current PWM X4	
Decode Channel	4CH	
DMX512 socket	XLR-3R port/ RJ45 port/ terminal block	
Dimension	L157xW65xH40(mm)	
Weight (G.W)	450g	

3. Basic Features

- Automatically adapts input voltage DC12V-48V.
- Input standard DMX512 signal; 3-digit display shows DMX address.
- 4 channels output; 4096 grey scales each channel; logarithmic dimming; lamp light soft & stable without strobe flash.
- Support master mode or slave mode;
- 8 color changing modes and 10 speed scales in master mode .
- Indicator of the DMX512 signal receiving status.
- Power loss memory function.
- DMX signal lines are wrong protection;
- Multiple DMX512 signal interface.

4. Safety warnings

- Please don't install this controller in lightning, intense magnetic and high-voltage fields.
- To reduce the risk of component damage and fire caused by short circuit, make sure correct connection.
 - Always be sure to mount this unit in an area that will allow proper ventilation to ensure a fitting temperature.
 - Check if the voltage and power adapter suit the controller (please select DC12-24V power supply with constant voltage)
 - Don't connect cables with power on; make sure a correct connection and no short circuit checked with instrument before power on.
 - Please don't open controller cover and operate if problems occur. The manual is only suitable for this model; any update is subject to change without prior notice.
 - More than 32 DMX decoders need to be connected a signal amplifier, and the signal amplification cannot exceed 5 times consecutively.
 - When the signal line is long or the wire quality causes the signal recoil effect to affect the use of product, you can try to connect 0.25W 90-120Ω terminating resistor at the end of each signal line to solve.

5. Dimensions

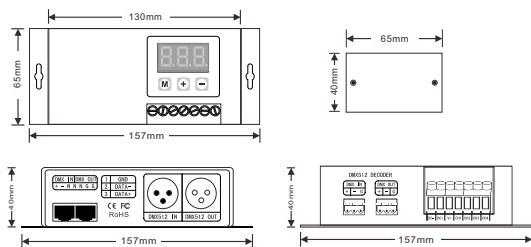

6. Operating instructions

Three touch buttons: M,+,-

M	Change order in 3 digital display
+	Increase value
-	Decrease value

Three-digit display indicates the current setting value; different value indicates different operating status. Three-digit display goes off without operation for 1 minutes, press any key to turn it on.

The decoder has an automatic key lock. If no settings are made to the decoder, the key lock function is activated after approximately 15 seconds automatically. Pressing M button for about 2 seconds to deactivated. Subsequently, the decoder can be set.

1. DMX Slave Mode: The value is: 001-512, such as: "001"



The decimal point of last digital of the display tube will twinkle regularly when receives DMX512 signal normally. When no signal is received, the decimal point does not twinkle, and showing current DMX address.

000	All channels to 100%	516	MAGENTA
513	RED	517	CYAN
514	GREEN	518	YELLOW
515	BLUE	519	ORANGE

520-529	red, orange, yellow, green, cyan, blue, magenta (Fading mode)
530-539	white, magenta, red, orange, yellow, green, cyan, blue (Fading mode)
540-549	yellow/orange, red (Fading mode)
550-559	magenta blue (Fading mode)
560-569	cyan, blue (Fading mode)
570-579	green, yellow, (Fading mode)
580-589	All 4 channels make a pulsating move from 1% to 100% (Fading mode)
590-599	Strobo for all 4 channels 0% to 100% (Jumping mode)
600-699	Red from 0 to 99%
700-799	Green from 0 to 99%
800-899	Blue from 0 to 99%
900-999	White from 0 to 99%

*520-599, First two digital indicate the modes, the third one shows the speed. 10 speed levels, from 0-9 speed decreasing. Total: 8 modes, such as:



Mode Speed level 4

Speed for Program 520 - 589 (Color Changing Fading Mode) for one step and not for the whole program:
 0=0,5 sec. | 1=1 sec. | 2=2 sec. | 3=3 sec. | 4=5 sec. | 5=10 sec. | 6=15 sec. | 7=30 sec. | 8=60 sec. | 9=120 sec.
 Speed for Program 590 - 599 (one step and not for the whole program):
 0=0,02 sec. | 1= 0,04 sec. | 2=0,1 sec. | 3=0,2 sec. | 4=0,5 sec. | 5=1 sec. | 6=2 sec. | 7=5 sec. | 8=10 sec. | 9=15 sec.

2. Wiring Indication

1) wiring diagram of Slave Mode:

