



Factory : 7 Weier Road, Qishi Town, Dongguan City. guangdong province, China

Dongguan Tel: (769)82632725

Dongguan Fax: (769)82632735

Specification

Document No.: OSK-SPC- SK6813HV-09-6P-000

Product No.: SK6813HV-09-6P-000

Sample numbe.: OP000138B -000

Description: 5.4x5.0x1.6mm top SMD 0.15W light source intelligent control 12V LED (5a)

Rev. No.: A/2

Date: 2023-05-09

Customer approval			Opsco approval		
Approval	Audit	Confirmati on	Approval	Review	Confirmat ion
			朱更生	周凯	刘峰
<input type="checkbox"/> Qualified <input type="checkbox"/> Disqualified Stamp			Stamp		



* Before using our products, please search our official website to check the version of specifications. The version of product specifications is updated. We are sorry to fail to inform you in time. Please refer to the latest information on the official website.

* The copyright and final interpretation of the product belong to Dongguan Occidental Optoelectronics Technology Co., Ltd. If you have special specifications, please contact our engineering staff;

*Official website: <https://www.opscoled.com>



CONTENTS

1、Product overview.....	4
2、Main Application Field.....	4
3、Description.....	4
4、Mechanical Dimensions.....	5
5、PIN configuration.....	5
6、Recommended dimensions for PCB products.....	5
7、General description of product naming.....	6
8、Electrical parameters.....	6
9、Electrical/Optical Characteristics.....	6
10、The IC electrical parameters.....	7
11、Switching characteristics.....	7
12、The data transmission time.....	8
13、Timing waveform.....	8
14、The method of data transmission.....	8
15、The data structure of 24bit.....	8
16、Standard LED Performance Graph.....	9
17、Packaging Standard.....	10
18、Reliability Test.....	11



Factory : 7 Weier Road, Qishi Town, Dongguan City. guangdong province, China

Dongguan Tel: (769)82632725

Dongguan Fax: (769)82632735

1. Product Overview :

SK6813HV-09-6P-000 is a smart LED control circuit and light emitting circuit in one controlled LED source, which has the shape of a 5050 LED chip. Each lighting element is a pixel, and the intensities of the pixels are contained within the intelligent digital interface input. The output is driven by patented PWM technology, which effectively guarantees high consistency of the color of the pixels. The control circuit consists of a signal shaping amplification circuit, a built-in constant current circuit, and a high precision RC oscillator.

The data protocol being used is unipolar RZ communication mode. The 24-bit data is transmitted from the controller to DIN of the first element, and if it is accepted it is extracted pixel to pixel. After an internal data latch, the remaining data is passed through the internal amplification circuit and sent out on the DO port to the remaining pixels. The pixel is reset after the end of DIN. Using automatic shaping forwarding technology makes the number of cascaded pixels without signal transmission only limited by signal transmission speed.

The LED has a low driving voltage (which allows for environmental protection and energy saving), high brightness, scattering angle, good consistency, low power, and long life. The control circuit is integrated in the LED above.

2. Main Application Field:

- Full color LED string light, LED full color module, LED super hard and soft lights, LED guardrail tube, LED appearance / scene lighting
- LED point light, LED pixel screen, LED shaped screen, a variety of electronic products, electrical equipment etc..

3. Description:

- Top SMD internal integrated high quality external control line serial cascade constant current IC;
- control circuit and the RGB chip in SMD 5050 components, to form a complete control of pixel, color mixing uniformity and consistency;
- built-in data shaping circuit, a pixel signal is received after wave shaping and output waveform distortion will not guarantee a line;
- The built-in power on reset and reset circuit, the power does not work;
- gray level adjusting circuit (256 level gray scale adjustable);
- red drive special treatment, color balance;
- line data transmission;
- plastic forward strengthening technology, the transmission distance between two points over 10M;
- Using a typical data transmission frequency of 800 Kbps, when the refresh rate of 30 frames per sec

4. Mechanical Dimensions:

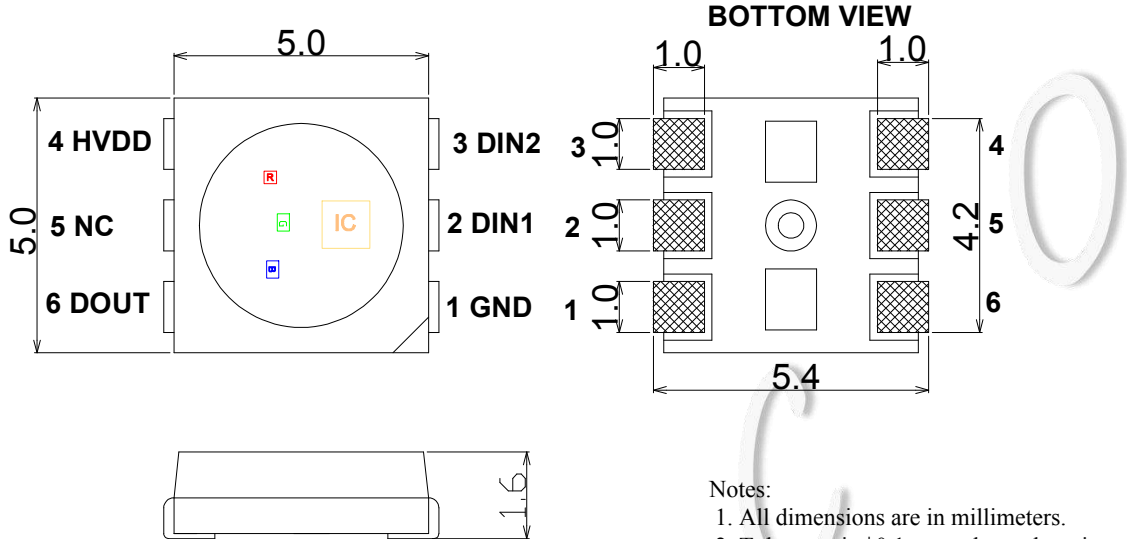

Notes:

1. All dimensions are in millimeters.
2. Tolerance is ± 0.1 mm unless otherwise noted

5. PIN configuration

Item	Symbol	Pin Name	Function description
1	GND	Ground	power ground
2	DIN 1	Data Input	control signal input data
3	DIN 2	Thermal data processing	Thermal data signal processing
4	HVDD	Power	power supply pin
5	NC	NC	NC
6	DOUT	Data Output	control signal output data

6. Recommended dimensions for PCB products

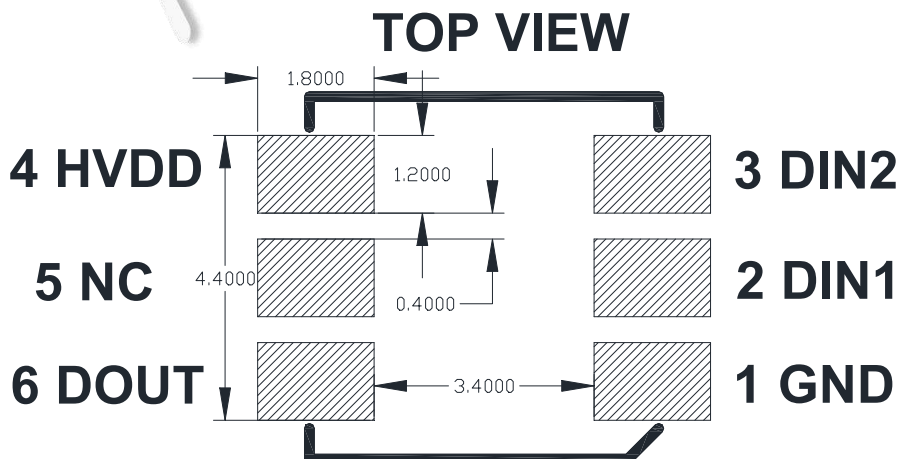



Factory : 7 Weier Road, Qishi Town, Dongguan City. guangdong province, China

Dongguan Tel: (769)82632725

Dongguan Fax: (769)82632735

7. General description of product naming.

SK 6813HV-09-6P-000

①
②
③
④

①	②	③	④
Series	IC series and current code	Foot position	Internal code
The default is to integrate the RGB chip with the IC	Refers to the 6813 series IC HV: High voltage version 09: 9mA	6P: refers to 6 feet;	000: internal code

8. Absolute Maximum Ratings (Ta=25°C, VSS=0V) :

Parameter	Symbol	Range	Unit
Power supply voltage	VDD	+0.4~+13	V
Logic input voltage	VIN	-0.5~VDD+0.5	V
Working temperature	Topt	-40~+80	°C
Storage temperature	Tstg	-40~+80	°C
ESD pressure(HBM)	VESD	2K	V
ESD pressure(DM)	VESD	200	V

9. Electrical/Optical Characteristics:

Color	SK6813HV-09-6P-000 9mA	
	Dominate avelength(nm)	Luminance(mcd)
Red	620-625	200-385
Green	515-525	580-1050
Blue	455-465	100-200

Factory : 7 Weier Road, Qishi Town, Dongguan City. guangdong province, China

Dongguan Tel: (769)82632725

Dongguan Fax: (769)82632735

10. The IC electrical parameters (unless otherwise specified, TA=-20 ~ +70 °C):

Parameter	Symbol	Min	Typical	Max	Unit	Test conditions
The chip supply voltage	VDD	10.8	12	13.2	V	---
The signal input flip threshold	VIH	4.0	---	---	V	---
	VIL	---	---	1.0	V	
The frequency of PWM	FPWM	---	8	---	KHZ	---
Static power consumption	IDD	---	2	---	mA	---

11. Switching characteristics (Ta=25 °C):

Parameter	Symbol	Min	Typical	Max	Unit	Test conditions
The speed of data transmission	fDIN	---	800	---	KHZ	The duty ratio of 67% (data 1)
DOUT transmission delay	TPLH	---	---	500	ns	DIN→DOUT
	TPHL	---	---	500	ns	

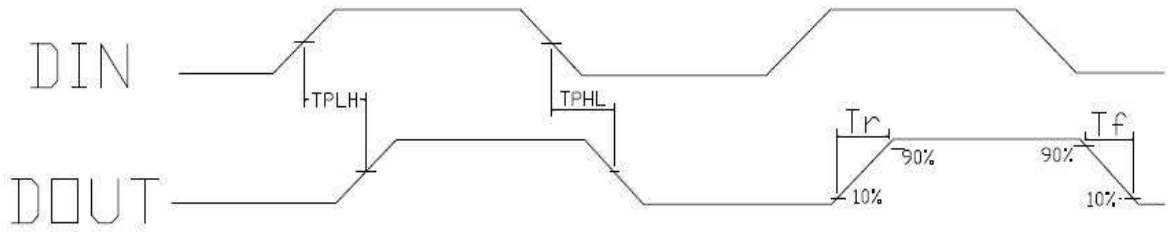

12. The data transmission time (TH+TL=1.25μs±600ns):

Name	Min.	Standard value	Max.	Unit	
T	Code period	1.20	--	μs	
T0H	0 code, high level time	0.2	0.25	0.4	μs
T0L	0 code, low level time	0.8	--	--	μs
T1H	1 code, high level time	0.65	0.75	1.0	μs
T1L	1 code, low level time	0.2	--	--	μs
Trst	Reset code , low level time	≥80	--	--	μs

13. Timing waveform:

Input code:

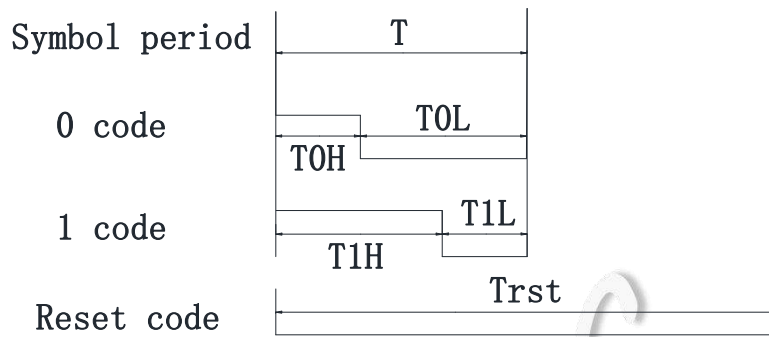

14. The method of data transmission:

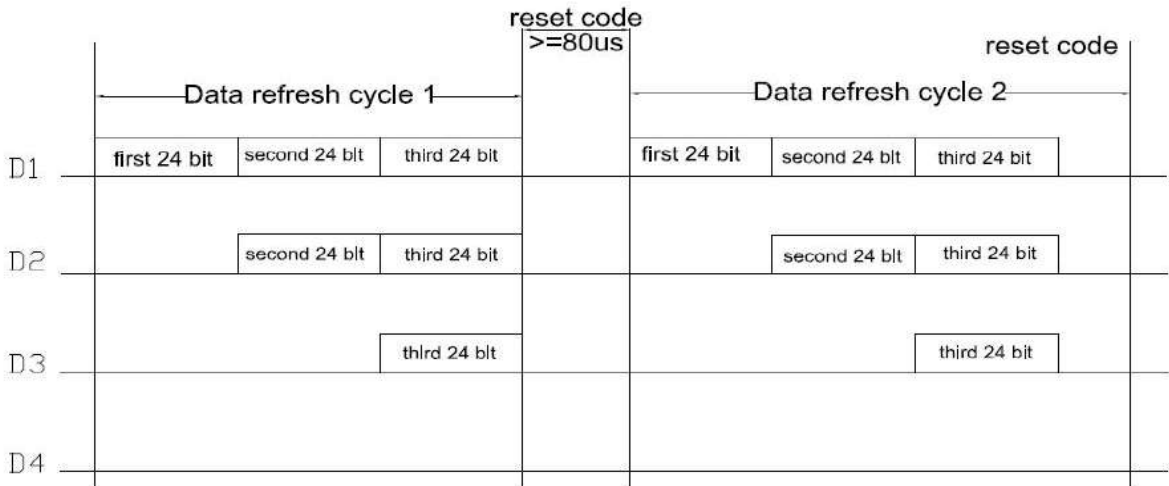

Note: the D1 sends data for MCU, D2, D3, D4 for data forwarding automatic shaping cascade circuit.

15. The data structure of 24bit:

R7	R6	R5	R4	R3	R2	R1	R0	G7	G6	G5	G4
G3	G2	G1	G0	B7	B6	B5	B4	B3	B2	B1	B0

Note: high starting, in order to send data (R7 - R6 -B0)

17. Standard LED Performance Graph:

Thermal Pad Temperature vs. Relative Light Output

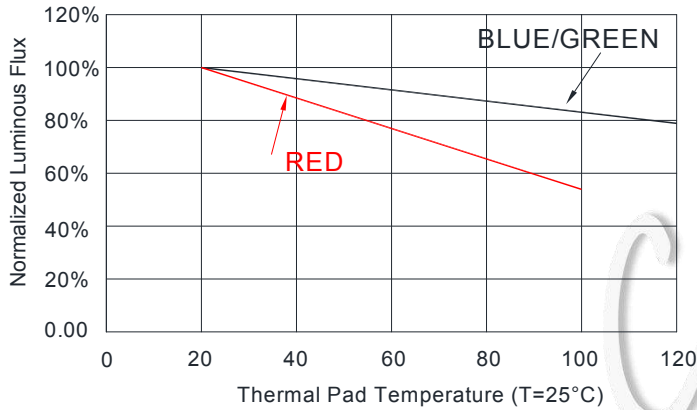

Wavelength Characteristics

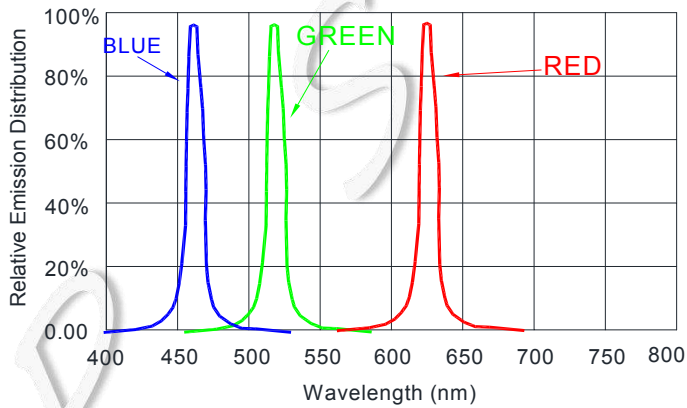

Typical Radiation Pattern 120°

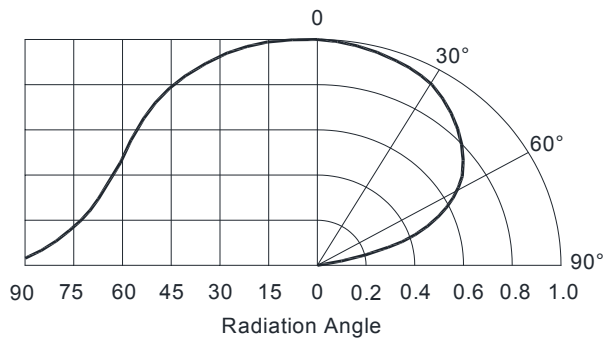

Factory : 7 Weier Road, Qishi Town, Dongguan City. guangdong province, China

Dongguan Tel: (769)82632725

Dongguan Fax: (769)82632735

18. Packaging Standard:

SK6813HV-09-6P-000

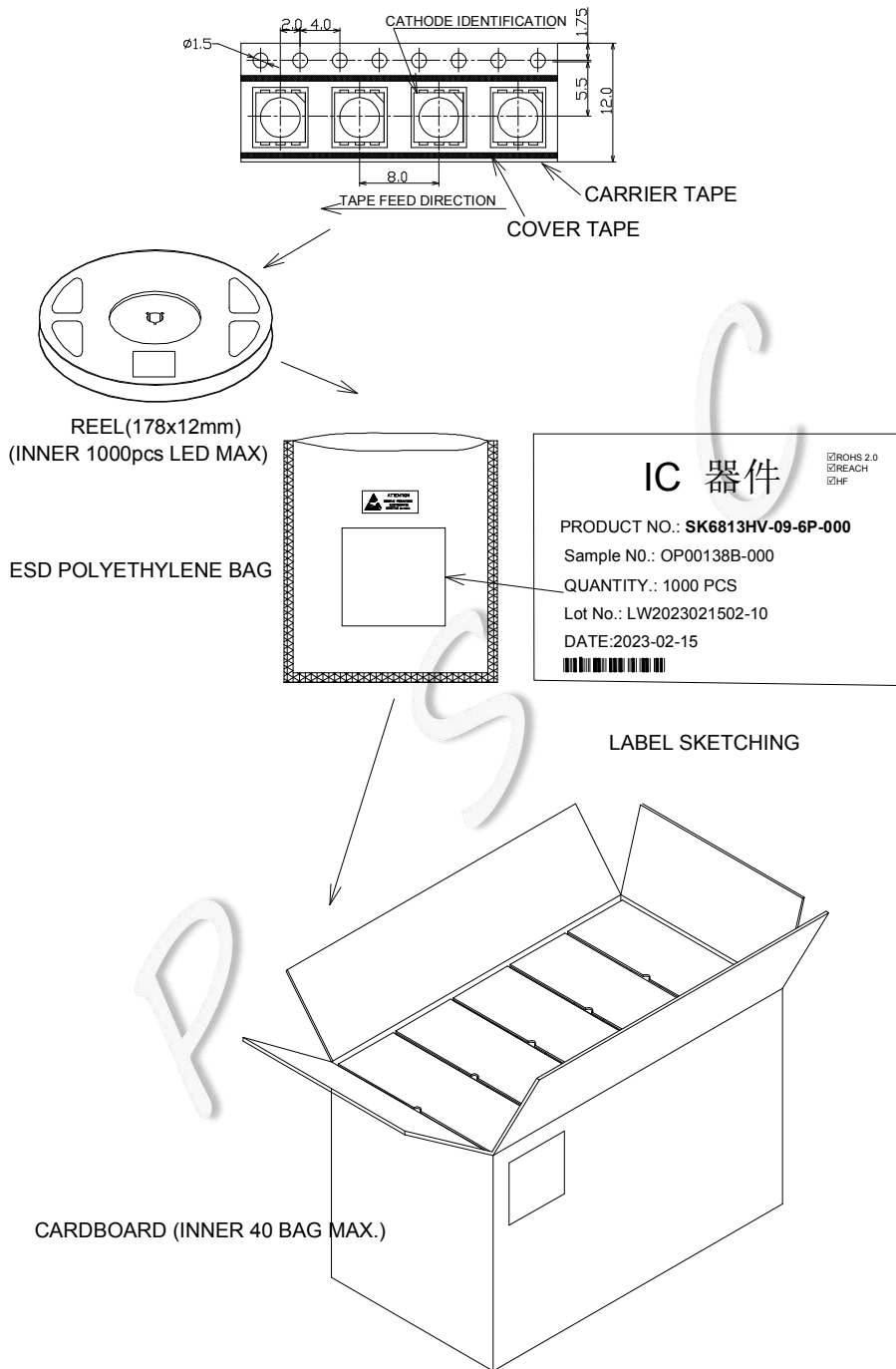

The reel pack is applied in SMD LED. The LEDs are packed in cardboard boxes after packaging in normal or anti-electrostatic bags. cardboard boxes will be used to protect the LEDs from mechanical shocks during transportation. The boxes are not water resistant and therefore must be kept away from water and moisture.



Factory : 7 Weier Road, Qishi Town, Dongguan City. guangdong province, China

Dongguan Tel: (769)82632725

Dongguan Fax: (769)82632735

19. Reliability Test :

NO.	Test item	Test Conditions	Reference	Criterion
1	Thermal Shock	100 ± 5° C ~ -40° C ± 5° C 30min~30min 100 cycles	MIL-STD-202G	0/22
2	High Temperature Storage	Ta= +100°C 1000hrs	JEITA ED-4701 200 201	0/22
3	Low Temperature Storage	Ta= -40°C 1000hrs	JEITA ED-4701 200 202	0/22
4	High Temperature High Humidity Storage	Ta=60°C RH=90% 1000hrs	JEITA ED-4701 100 103	0/22
5	Temperature Cycle	-40°C~25°C~100°C~25°C 30min~5min~30min~5min 100 cycles	JEITA ED-4701 100 105	0/22
6	Resistance to Soldering Heat	Tsld = 260° C, 10sec. 2 times	JEITA ED-4701 300 301	0/22
7	Room temp Life Test	25° C, IF: Typical current , 1000hrs	JESD22-A 108D	0/22

Criteria for Judging the Damage:

Item	Symbol	Test Condition	Limit	
			Min	Max
Luminous Intensity	IV	DC=12V, Typical current	Init. Value*0.7	---
Resistance to Soldering Heat	---	DC=12V, Typical current	No dead lights or obvious damage	